



Cooled and warm air

Smartcap High IonStar

De Smartcap High IonStar met WS 450 wervelrooster: voor gekoelde/verwarmde luchttoevoer in diverse ruimtes. Inbouw in systeemplafonds. Hoge inductie, snelle temperatuuregalisatie.

Smartcap High IonStar with WS 450 swirl diffuser: for cooled/heated air supply in various spaces. Installation in suspended ceilings. High induction, rapid temperature equalization.

Smartcap High IonStar mit WS 450 Wirbelauslass: für gekühlte/erwärmte Luftzufuhr in verschiedenen Räumen. Einbau in Systemdecken. Hohe Induktion, schneller Temperatureausgleich.

Benefits / Vorteile

Voordelen Smartcap High IonStar



- Gezonde lucht
- Effectieve reiniging: 99,7%
- Doodt virussen, bacteriën, sporen en schimmels
- Effectiever dan G-, F- of HEPA-filters
- Constante werking
- Geen Pascalwerking
- Energiezuinig: < 2 Watt
- Eenvoudige installatie
- Wetenschappelijk onderbouwd



- Healthy air
- Effective purification: 99.7%
- Eliminates viruses, bacteria, spores, and molds
- More effective than G, F, or HEPA filters
- Continuous operation
- No Pascal effect
- Energy-efficient: < 2 Watts
- Easy installation
- Scientifically validated



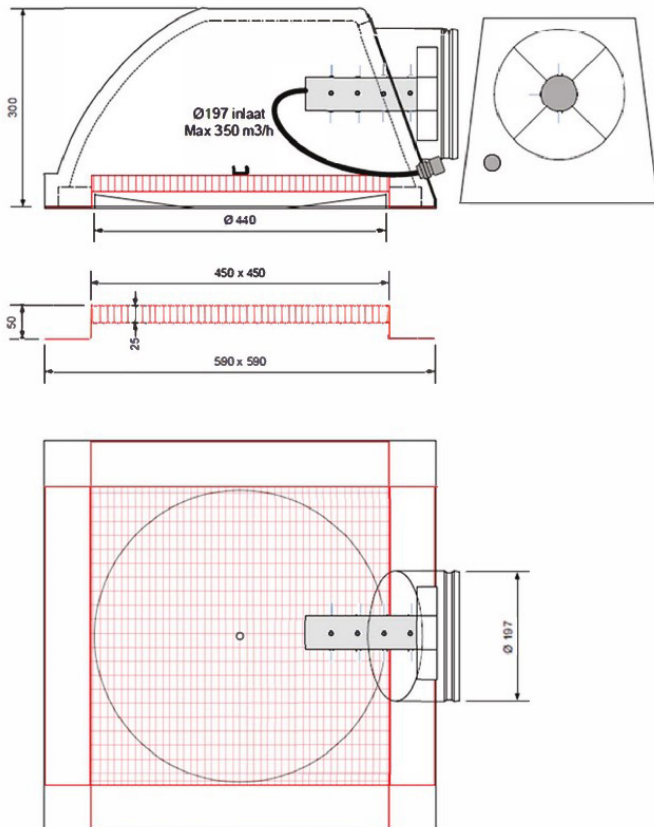

- Gesunde Luft
- Effektive Reinigung: 99,7%
- Tötet Viren, Bakterien, Sporen und Schimmelpilze ab
- Effektiver als G-, F- oder HEPA-Filter
- Kontinuierlicher Betrieb
- Kein Pascal-Effekt
- Energieeffizient: < 2 Watt
- Einfache Installation
- Wissenschaftlich belegt





Type deeltjes	Efficiëntie
Deeltjesfractie	0,3 - 7 µm 99,94 %
Schimmelsporen = 100 µm	97 %
Bacteriën = 100 µm	98 %

Omschrijving	Ionstroom
Merk	Freshcare
Type	Ionstroom
Afmeting	590x590x300mm
Frontrooster	450mm
SGF filter	350x350x25mm
Diameter aansluiting	200mm
Capaciteit	350 m ³ /h
Garantie	1 jaar
Verpakking	Per stuk
Doosverpakking	600x700x35mm
Opgenomen vermogen	2W
Voltage	230 volt / 50-60hz
Kanaalaansluiting	Ø200mm
Certificering	CE, ROHS, TUV
Energie-efficiëntie	A++
Installatie	Boven plafond
Bediening	Centraal of handmatig

 EPP ISO plumbak, lonstar, statisch geladen filter en wervelrooster. Even effectief als HEPA-filter, maar met lagere weerstand door ionisatietechnologie. Resulteert in energiezuinige en efficiënte luchtreiniging.

 EPP ISO plenum box, lonstar, statically charged filter, and swirl diffuser. As effective as HEPA filter, but with lower resistance through ionization technology. Results in energy-efficient and effective air purification.

 EPP ISO Plenumkasten, Lonstar, statisch aufgeladener Filter und Wirbelauslass. So effektiv wie HEPA-Filter, aber mit geringerem Widerstand durch Ionisationstechnologie. Führt zu energieeffizienter und wirksamer Luftreinigung.

 **Plenum:** EPP ISO plumbak: licht (800g), vochtbestendig, stapelbaar. Bespaart op montage-, transport- en opslagkosten. Hoge thermische isolatiewaarde: 0,040 W/(m·K).

Ionisatie: Geïntegreerde ionstar laadt luchtdeeltjes statisch. SGF-filter vangt deeltjes af. Beschikbaar in verschillende voltages.

SGF (statisch geladen filter): Vangt geladen deeltjes af, inclusief ultrafijnstof, bacteriën en virussen. Eenvoudig te vervangen dankzij scharnieren en push-pull sluitingen.

 **Plenum:** EPP ISO plenum box: lightweight (800g), moisture-resistant, stackable. Saves on installation, transport, and storage costs. High thermal insulation value: 0.040 W/(m·K).

Ionization: Integrated ionstar statically charges air particles. SGF filter captures particles. Available in various voltages.

SGF (Statically Charged Filter): Captures charged particles, including ultrafine dust, bacteria, and viruses. Easy replacement thanks to hinges and push-pull closures.

 **Plenum:** EPP ISO Plenumkasten: leicht (800g), feuchtigkeitsbeständig, stapelbar. Spart Montage-, Transport- und Lagerkosten. Hoher Wärmedämmwert: 0,040 W/(m·K).

Ionisation: Integrierter Ionstar lädt Luftpartikel statisch auf. SGF-Filter fängt Partikel auf. In verschiedenen Spannungen erhältlich.

SGF (Statisch geladener Filter): Fängt geladene Partikel auf, einschließlich Ultrafeinstaub, Bakterien und Viren. Einfacher Austausch dank Scharnieren und Push-Pull-Verschlüssen.





Contact us / Kontaktieren Sie uns Contact met SMARTCAP

mail: m.stober@smartcapbyrs.de
fon: 049 71186054593

Vertrieb

SMARTCAP Entwicklungen

Hauptmannsreute 26

70192 Stuttgart

